

Evaluate New Designs and Improve Your Installed Systems

AFT Arrow is practical fluid dynamic simulation software used to calculate pressure drop and flow distribution in gas piping and ducting systems. Designed for compressible flow systems containing steam, compressed air, chemical and petrochemical process gases, natural gas transport and more, AFT Arrow is an indispensable tool to help you tackle your most challenging systems.



Capabilities

- Experiment with operating conditions and scenarios
- Quickly and easily change system input data, including valve positions, compressor operation, control set points, pressures, temperatures and more
- Model a wide range of system components for both design and operational cases
- Select ideal or real gases
- Choose between isothermal, adiabatic or generalized heat transfer conditions
- Vary your system lineup: open and close pipes and valves, turn compressors or fans on or off, set control valves to fail position
- Conduct flow analysis with high velocities including sonic choking
- Compile libraries of your frequently used components and quickly select them from a drop down list
- Assemble non-reacting mixtures and analyze dynamic mixtures resulting from intersecting flow streams
- Model rotating piping systems such as those found in steam and gas turbines
- Model effects of elevation changes such as in tall structures, subsurface mines and overland pipelines

Benefits

- Understand the fluid dynamic and thermodynamic behavior of your system
- Predict how pipes, valves, compressors, fans and other components will interact with each other
- Evaluate the performance of new designs
- Assure all design requirements are met
- Identify and correct operational problems
- Produce less costly, more efficient and more reliable piping systems

Typical Applications

- Pipe and duct sizing
- Relief valve sizing and system calculations
- Compressor and fan sizing and selection
- Control valve sizing and selection
- Simulating system operation and component interaction
- Choked flow calculations
- Evaluating pipe insulation and heat transfer in pipes and heat exchangers
- Troubleshooting existing systems

Features

- Advanced marching methods provide highly accurate results
- Detailed modeling for fans and compressors, control valves, heat exchangers and other components
- Conduct compressor and fan energy cost analysis
- Conduct thermal analysis including piping heat transfer and heat exchanger modeling
- Scenario Manager tracks all design variants and operational possibilities in a single model file
- Integrated graphing and reporting
- Built-in library of gases and fittings can be extended and customized
- Built-in ASME steam properties
- Optional Chempak™ add-on utility provides a thermophysical database of almost 600 gases - allows you to define non-reacting pre-mixtures and simulate dynamic flow mixing

AFT Arrow add-on modules:

- Goal Seek and Control (GSC) - automates identification of input parameters that yield desired output values and simulates control functions
- Cost (CST) - calculates the cost of pipes and components
- The modules can work individually or together and used with your existing AFT Arrow models.

How does it work?

AFT Arrow's powerful solution engine simultaneously solves five fundamental equations; mass, momentum, energy, state and Mach number. It uses a modified Newton - Raphson matrix iteration method plus proprietary methods developed by AFT so you can achieve a true and rigorous compressible flow solution.

Get the most out of your AFT Arrow software investment

Training by our professional staff helps you learn about the software's wide range of capabilities and modeling techniques. Our seminars review fundamental theory, basic through advanced techniques and hands-on modeling. Whether you're a new or experienced user, you'll find an AFT Arrow seminar a worthwhile investment of your time. AFT offers regularly scheduled seminars at our offices in the USA. Seminars can also be held at your facility.

Visit www.aft.com/learning-center/seminars for more information.

"AFT Arrow", "Applied Flow Technology", "Dynamic solutions for a fluid world" and the AFT logo are trademarks of Applied Flow Technology Corporation. "Chempak" is a trademark of Madison Technical Software Inc.

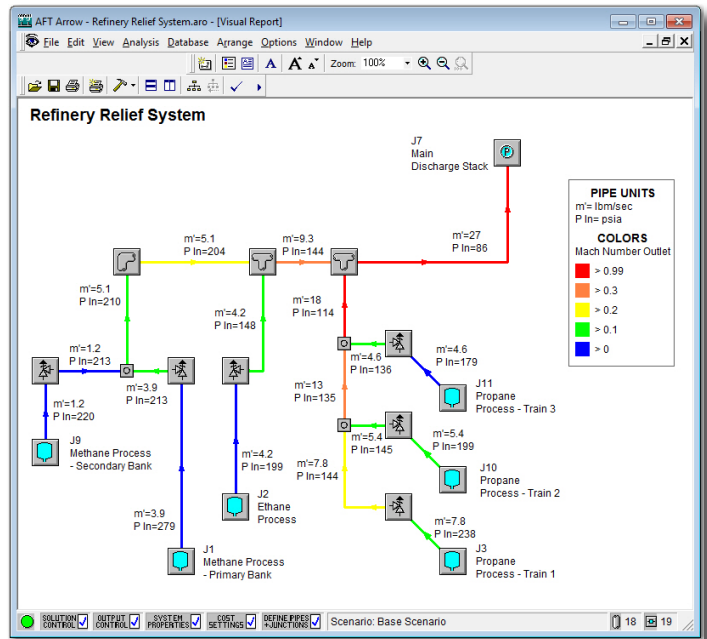
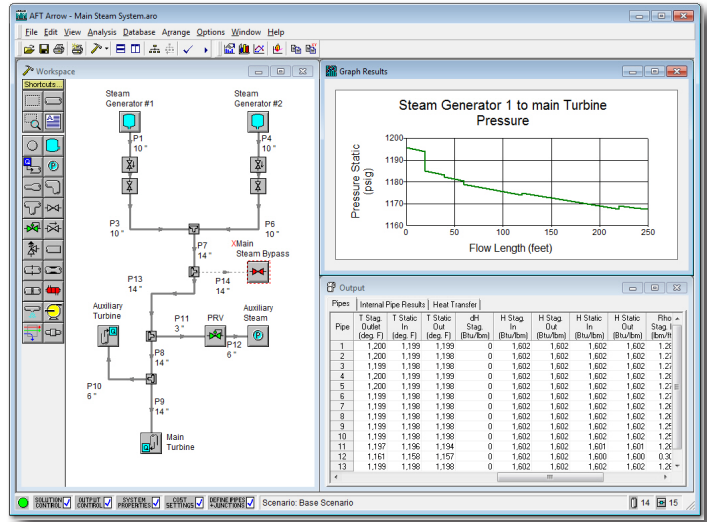

World class support

Your software purchase includes a free year of product upgrades and technical support provided by our team of professional engineers. We provide the knowledge that comes with extensive real world experience.



2955 Professional Place, Suite 301
 Colorado Springs, CO 80904 USA
 (719) 686 1000
sales@aft.com
www.aft.com